

# Dust Cyclone GTS



*Excellent Milling Properties...*

## WORKING PRINCIPLES

Machine is used for separate dust particles in dust-air mixes.



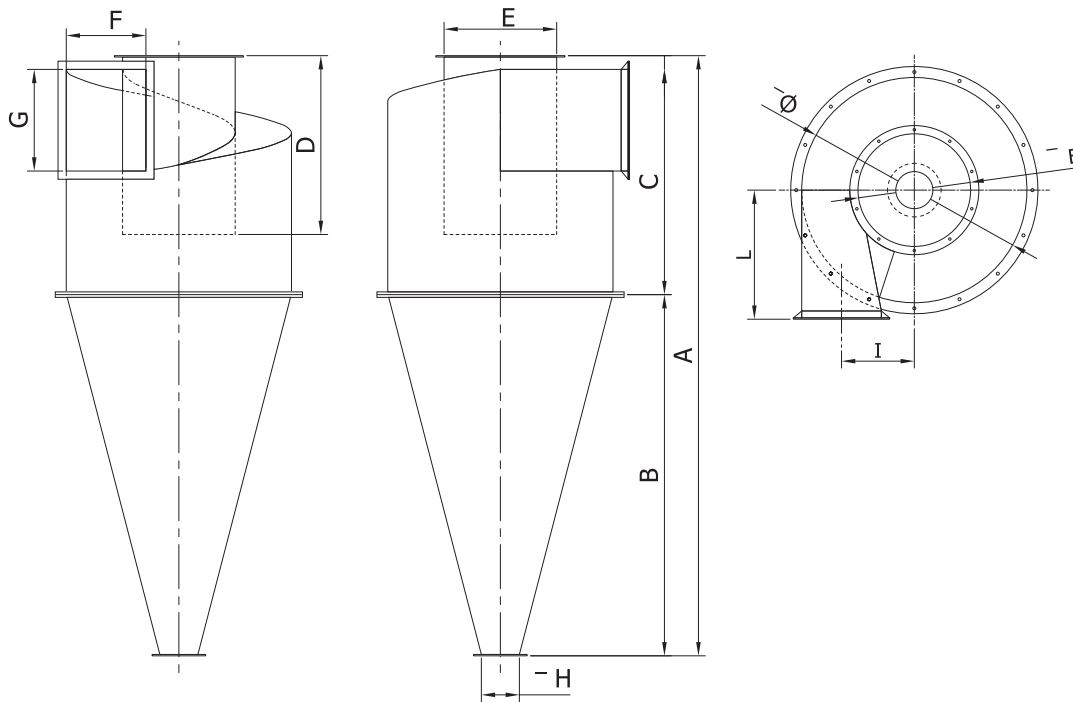

Type	Technical Features			Dimensions (mm)									
	Cylinder Diameter	Air Required		A	B	C	D	E	F	G	H	I	L
		m <sup>3</sup> /min	mmwg										
GTS 080	Ø 820	50/70	50 / 80	2185	1315	820	651	410	290	370	135	265	440
GTS 100	Ø 960	75/100	50 / 80	2608	1598	960	750	480	340	430	135	310	510
GTS 110	Ø 1100	80/114	50 / 80	3028	1876	1100	850	550	390	495	135	405	580
GTS 130	Ø 1300	108/158	50 / 80	3500	2150	1300	920	650	460	580	135	420	670
GTS 150	Ø 1500	150/215	50 / 80	4000	2450	1500	1080	750	530	690	135	485	770
GTS 170	Ø 1700	190/270	50 / 80	4500	2750	1700	1220	850	600	780	135	550	870